

AUTO REVERSE DOCUMENT FEEDER

(Machine Code: B597)



1. REPLACEMENT AND ADJUSTMENT

1.1 COVERS

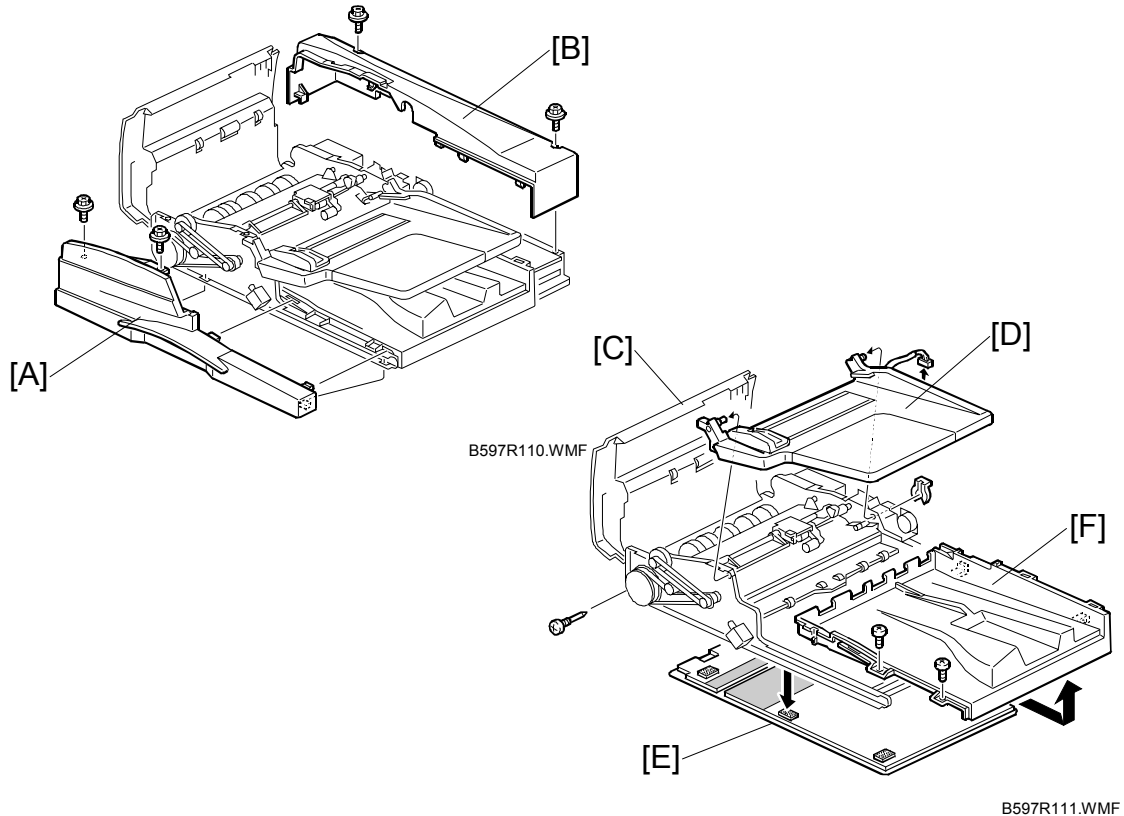

- [A]: Front cover (⚙ x 2)
- [B]: Rear cover (⚙ x 2)
- [C]: Top cover (⚙ x 1, 📌 x 2)
- [D]: Original tray (📌 x 1, 📌 x 1)
- [E]: Platen sheet (Velcro pads)
- [F]: Original exit tray (⚙ x 2). Slide to the right and then pull out.

⚠ CAUTION

The hinge of the ARDF is spring-loaded and becomes much lighter with all the covers removed. After removing all the covers, lay a heavy book on the front right corner of the ARDF to prevent it from springing up unexpectedly.

1.2 ORIGINAL FEED UNIT

Open the top cover.

- [A]: Original feed unit
Press it toward you on its shaft to release and lift out.

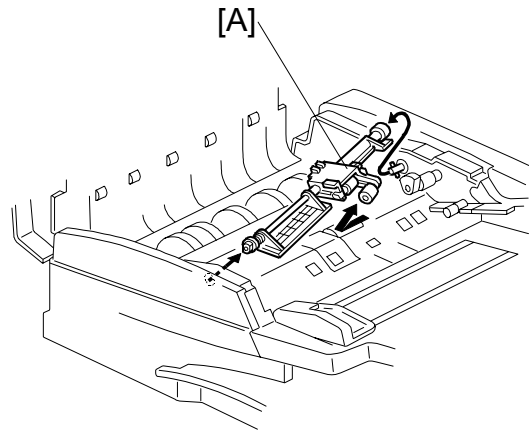

B597R101.WMF

1.3 ORIGINAL PICK-UP ROLLER

Original feed unit (☛ 1.2)

- [A]: Pick-up roller (🌀 x 1)

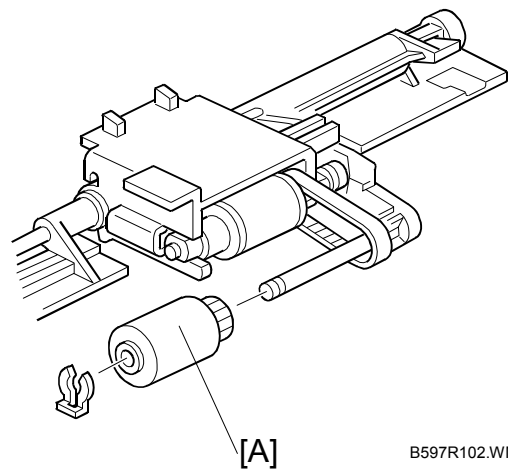

B597R102.WMF

1.4 ORIGINAL FEED BELT

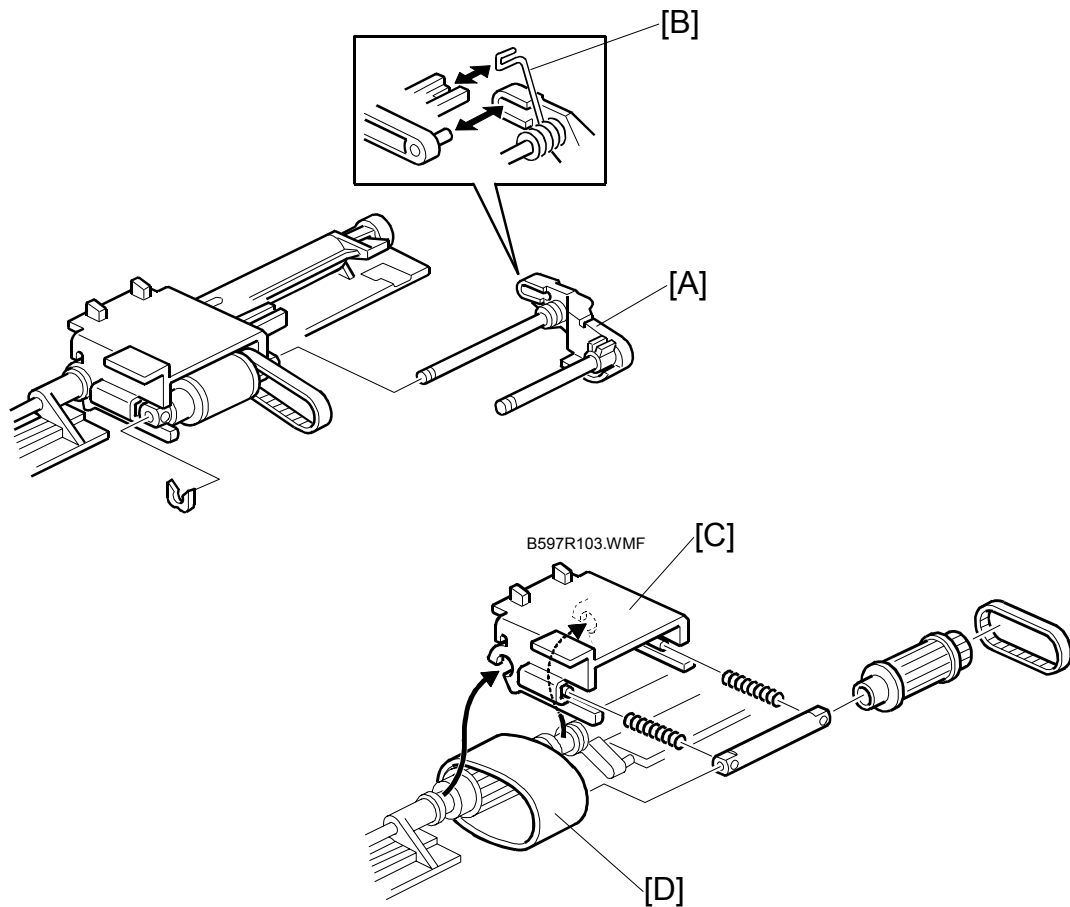

B597R104.WMF

Original feed unit and original pick-up roller (➔ 1.2, 1.3)

[A]: Shaft (☞ x 1)

NOTE: Before removing the shaft, note carefully the positioning of the spring [B]. This must be reset during re-installation.

[C]: Feed belt cover (Timing belt, gear, shaft, springs x 2)

NOTE: Do not lose the springs.

[D]: Original feed belt

1.5 SKREW CORRECTION/INTERVAL/ REGISTRATION/ORIGINAL WIDTH SENSORS

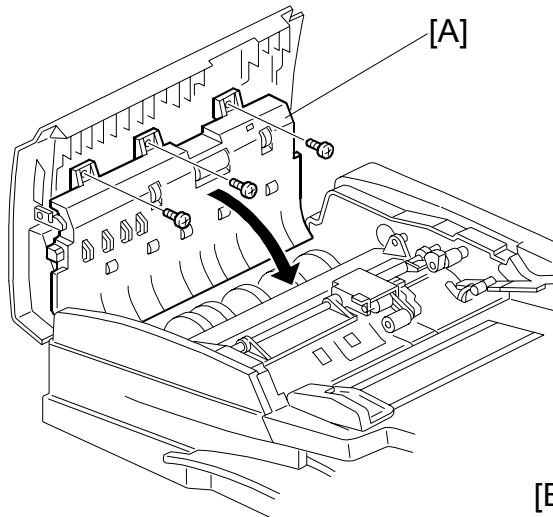

B597R105.WMF

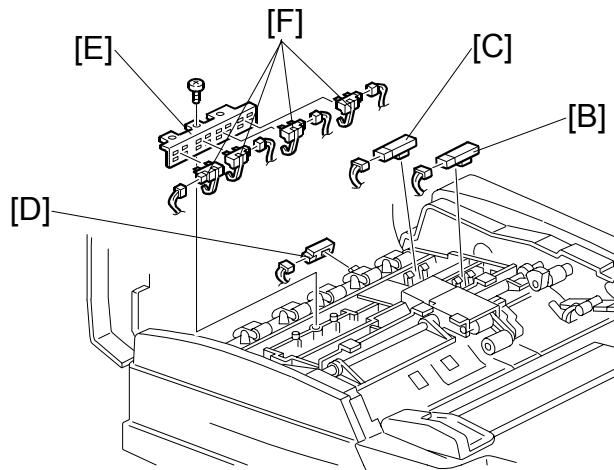

B597R106.WMF

Open the top cover.

- [A]: Upper original guide (🔩 x 3).
- [B]: Skew correction sensor (📏 x 1)
- [C]: Interval sensor (📏 x 1)
- [D]: Registration sensor (📏 x 1)
- [E]: Original width sensor bracket (🔩 x 1, 📏 x 4)
- [F]: Original width sensors

1.6 ORIGINAL LENGTH SENSORS

Raise the original table.

[A]: Lower cover of original tray (🔩 x 4)

[B]: Original length sensor-1 (🔌 x 1)

[C]: Original length sensor-2 (🔌 x 1)

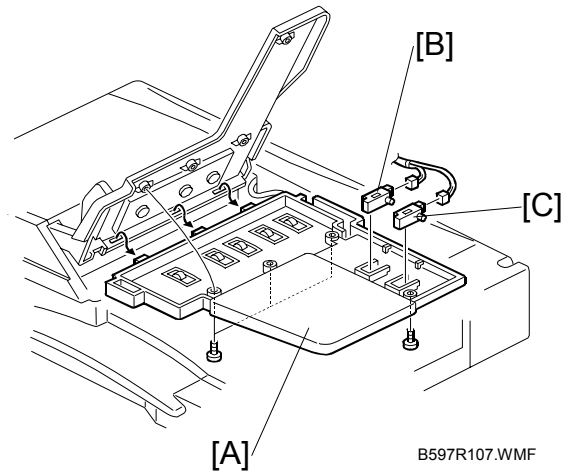

1.7 SEPARATION ROLLER

Original feed unit (👉 1.2)

[A]: Separation roller cover

[B]: Separation roller (🔩 x 1)

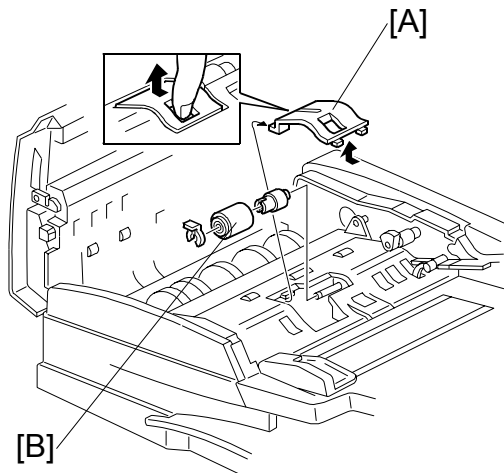

1.8 INVERTER /ORIGINAL SET SENSORS

Rear cover. (☛ 0)

[A]: Lower the original stopper by rotating the pick-up motor

Original feed unit (☛ 1.2)

[B]: Feed guide plate (☛ x 4, stepped screw)

NOTE: Raise the original tray before you re-install the paper feed guide.

Separation roller, torque limiter (☛ x 1) (☛ 1.7)

[C]: Bracket (☛ x 1, ☛ x 1)

[D]: Inverter sensor (☛ x 1)

[E]: Original set sensor (☛ x 1)

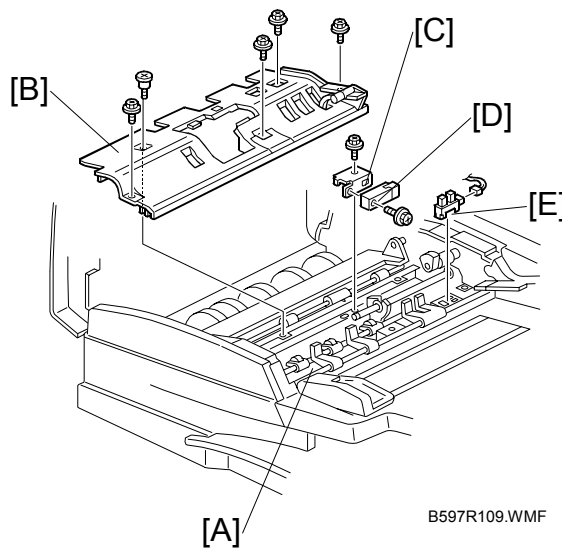

1.9 PICK-UP MOTOR/ORIGINAL STOPPER HP SENSOR/PICK-UP HP SENSOR

Rear cover (☛ 0)

[A]: Pick-up motor (☛ x 1, ☛ x 2, Timing belt)

[B]: Sensor bracket (☛ x 2, ☛ x 1)

[C]: Pick-up HP sensor

[D]: Original stopper HP sensor

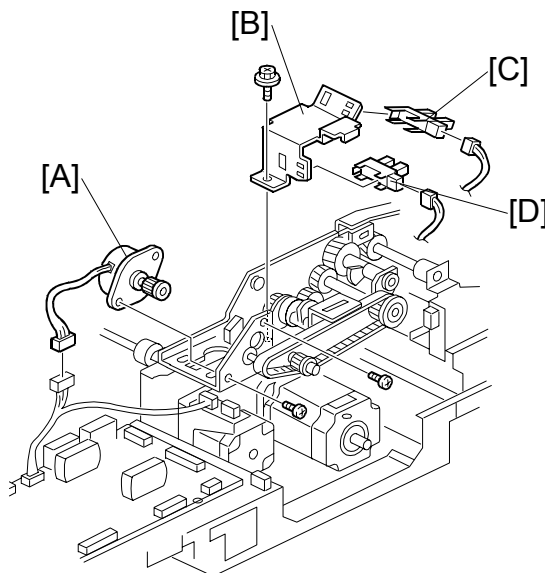

1.10 TRANSPORT MOTOR AND INVERTER MOTOR

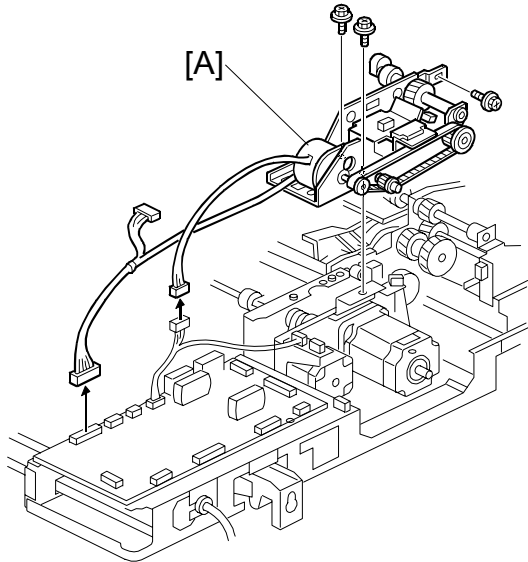

B597R113.WMF

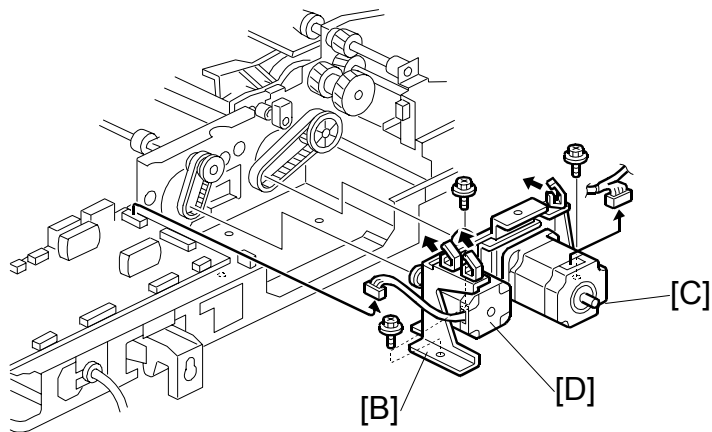

B597R112.WMF

Rear cover (0)

[A]: Pick-up roller assembly (1 x 1, 3 x 3, 3 x 3)

[B]: Motor bracket (3 x 3, 2 x 2, Timing belt x 2)

[C]: Transport motor (2 x 2, Spring x 1)

[D]: Inverter motor (2 x 2)

1.11 FEED MOTOR, SKEW CORRECTION ROLLER CLUTCH

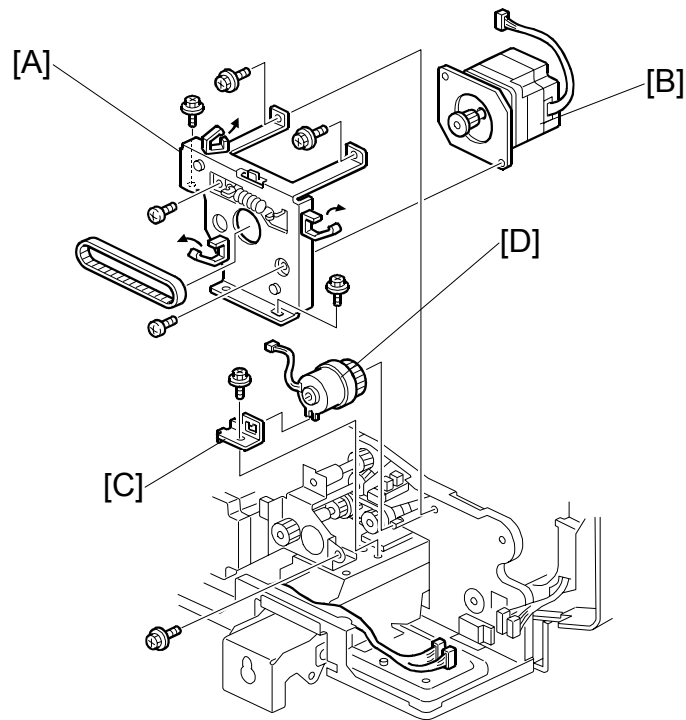

B597R115.WMF

Rear cover (☛ 0)

[A]: Motor bracket (☛ x 5, ☛ x 1)

[B]: Feed motor (☛ x 2)

[C]: Clutch stopper (☛ x 1)

[D]: Skew correction roller clutch (☛ x 1)

1.12 EXIT SENSOR

Open the ARDF.

[A]: Pull the platen sheet off halfway.

[B]: Open the exit guide plate.

[C]: Exit guide plate cover (🔩 x 2)

[D]: Exit sensor (🔩 x 1, 📡 x 1)

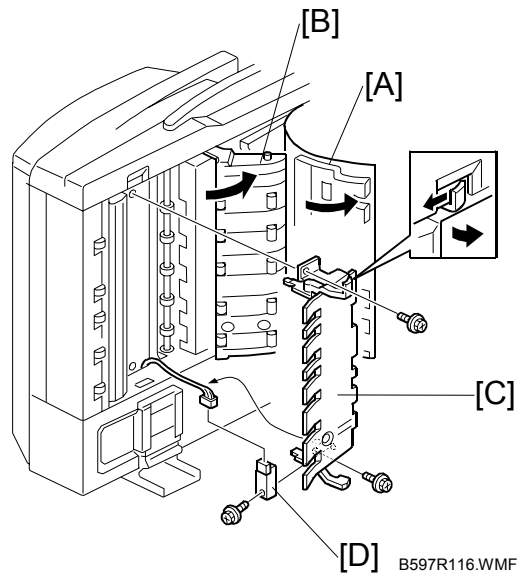

1.13 STAMP SOLENOID

Rear cover (🔩 0)

Open exit guide plate (🔩 1.12)

[A]: Exit guide plate cover (🔩 x 1)

[B]: Stamp solenoid (🔩 x 1, 📡 x 1)

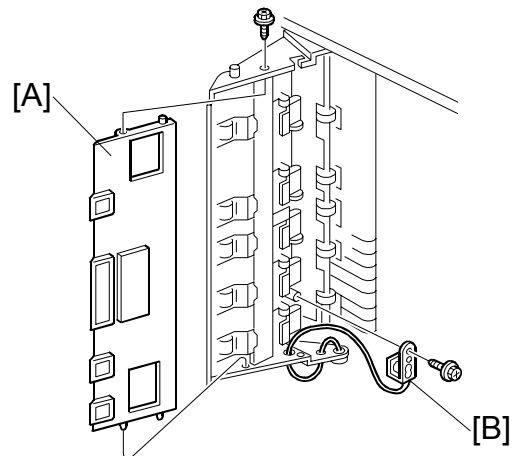

1.14 CONTROLLER BOARD

Rear cover (🔩 0)

[A]: Controller board (🔩 x 4, all 📡)

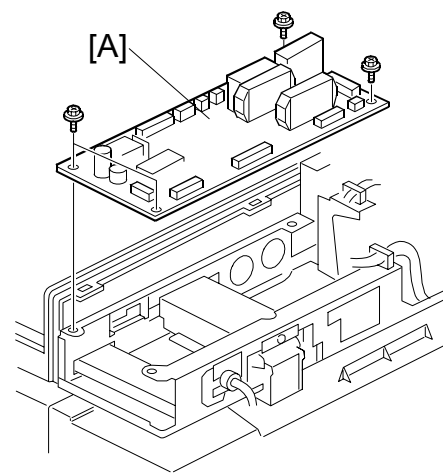

Peripherals

2. TROUBLESHOOTING

2.1 TIMING CHARTS

2.1.1 A4(S)/LT(S) SINGLE-SIDED ORIGINAL MODE

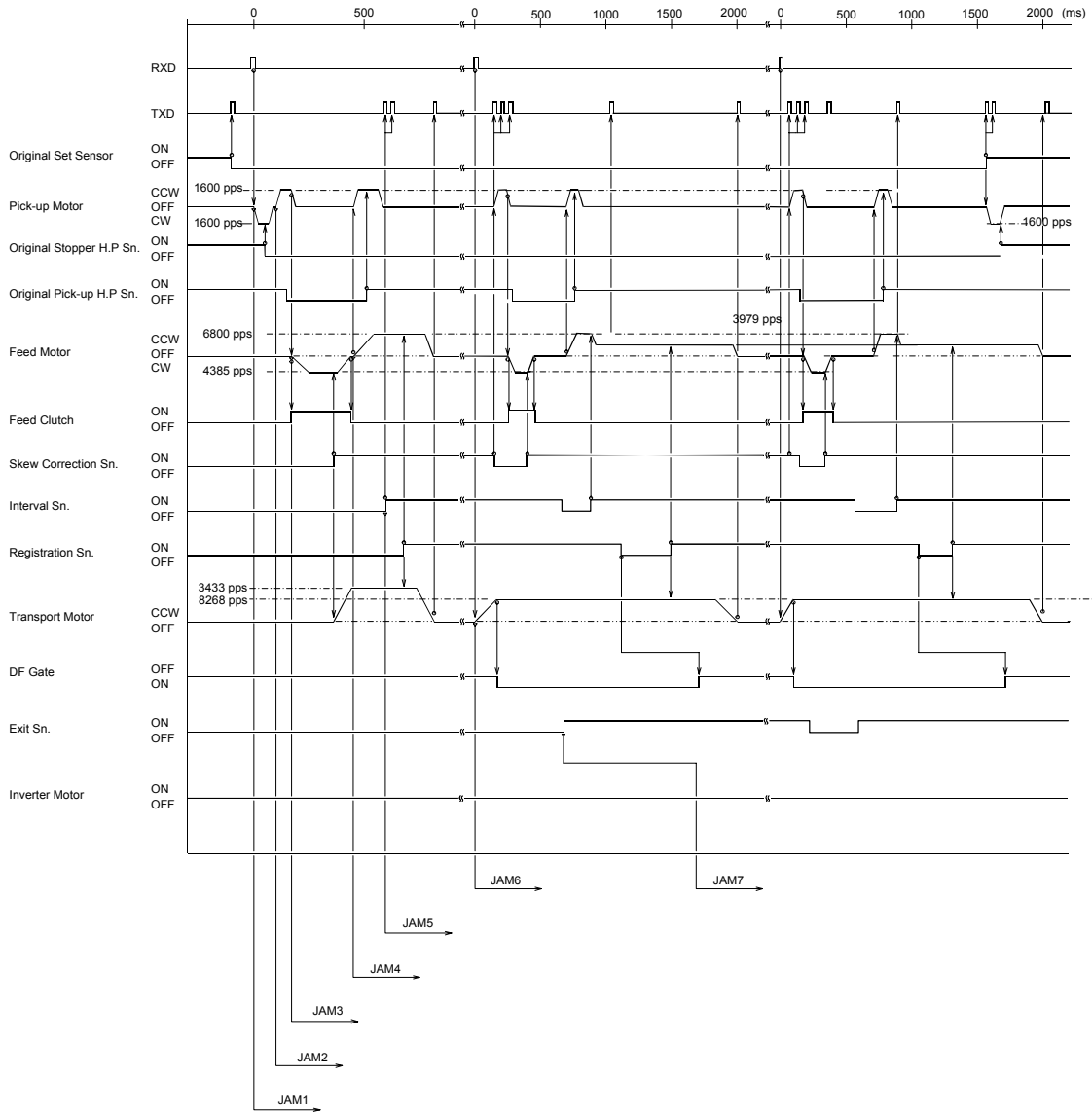

B597T900.WMF

2.1.2 A4(S)/LT(S) DOUBLE-SIDED ORIGINAL MODE

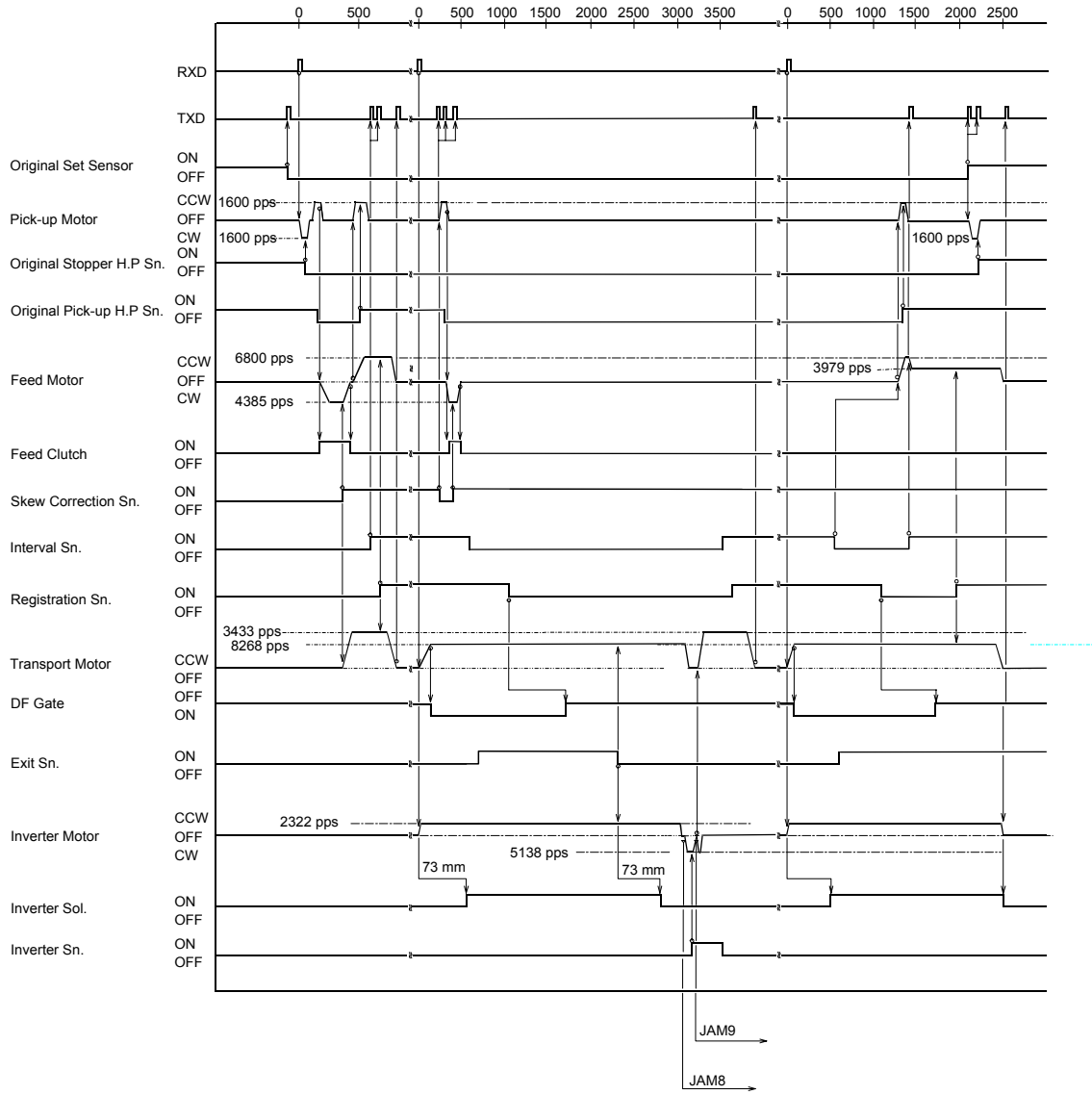

B597T901.WMF



2.2 JAM DETECTION

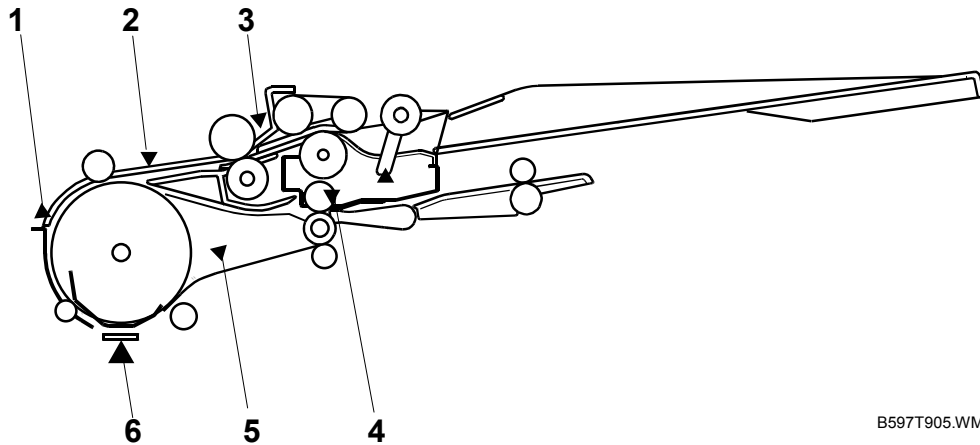

B597T905.WMF

- | | |
|---------------------------|----------------------|
| 1. Registration sensor | 4. Inverter sensor |
| 2. Interval sensor | 5. Exit sensor |
| 3. Skew correction sensor | 6. Scanning position |

Jam Site	Cause
Original stopper HP sensor (Jam 1)	Original stopper home position could not be detected within 1000 ms after the pick-up motor switched on and started rotating counter-clockwise.
Pick-up HP sensor (Jam 2)	Pick-up roller home position could not be detected within 1000 ms after the pick-up motor switched on and started rotating clockwise.
Skew correction sensor jam (Jam 3)	The skew correction sensor does not turn on after the feed motor has fed the original 185 mm.
Transport jam (Jam 4)	The interval sensor does not turn on after the feed motor has fed the original 141 mm.
Registration sensor (Jam 5)	The registration sensor does not turn on after the interval sensor turned on and the original has been fed 117 mm.
Exit jam (Jam 6)	The exit sensor does not turn on after the transport motor has fed the original 124 mm.
Exit jam (Jam 7)	The exit sensor does not turn off after the exit sensor turned on and the original has been fed 294 mm.
Inverter sensor jam (Jam 8)	The inverter sensor does not turn on after the inverter motor has fed the original 100 mm.
Interval sensor jam (Jam 9)	The interval sensor does not turn on after the inverter motor has fed the original 339 mm.

3. SERVICE TABLES

3.1 DIP SWITCHES

DPS101				Description
1	2	3	4	
0	0	0	0	Normal operating mode, with/without stamp.
0	0	0	1	Not used
0	0	1	0	Not used
0	0	1	1	Not used
0	1	0	0	Feed motor rotation (pull-out mode) 6800 pps (1-2 phase)
0	1	0	1	Feed motor rotation (feed mode) 4385 pps (1-2 phase)
0	1	1	0	Transport motor rotation 8268 pps (2W1-2 phase)
0	1	1	1	Inverter motor rotation 7720 pps (1-2 phase)
1	0	0	0	Free run: one-sided original 100% (color mode)
1	0	0	1	Free run: one-sided original 200% (color mode)
1	0	1	0	Free run: one-sided original 32% (color mode)
1	0	1	1	Free run: one-sided original 100% (b/w mode)
1	1	0	0	Free run: two-sided original 100% (color mode)
1	1	0	1	Free run: two-sided original 100% (b/w mode)
1	1	1	0	Free run: one-sided (fax mode) 48% (b/w mode)
1	1	1	1	Free run: one-sided (mixed original size mode) 100% (color mode)

3.2 TEST POINTS

No.	Label	Monitored Signal
TP100	(GND)	Ground
TP101	(Vcc)	+5V
TP103	(TXD)	TXD to the copier
TP104	(RXD)	RXD from the copier

3.3 FUSES

No.	Function
FU101	Protects the 24 V line.

4. DETAILED DESCRIPTIONS

4.1 MAIN COMPONENTS

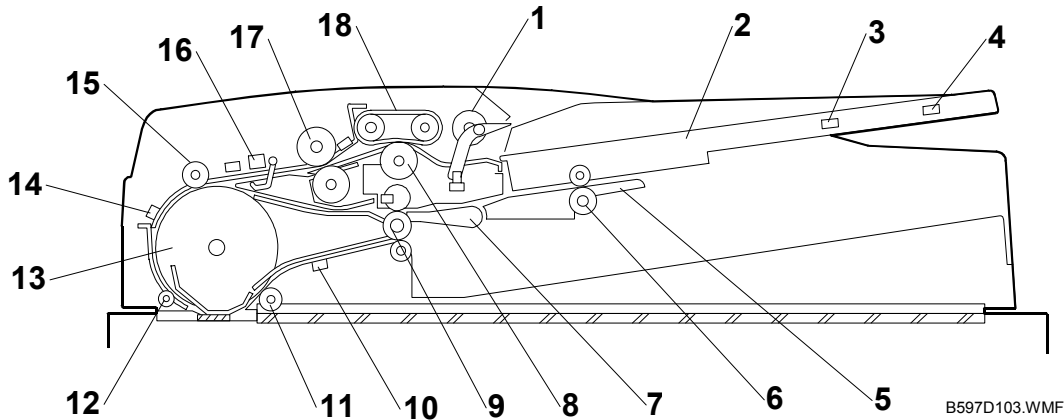

- | | |
|----------------------------|---------------------------|
| 1 Pick-up roller | 10 Exit sensor |
| 2 Original tray | 11 Idle roller 3 |
| 3 Original length sensor 1 | 12 Idle roller 2 |
| 4 Original length sensor 2 | 13 Transport roller |
| 5 Reverse table | 14 Registration sensor |
| 6 Inverter roller | 15 Idle roller 1 |
| 7 Junction gate | 16 Original width sensor |
| 8 Separation roller | 17 Skew correction roller |
| 9 Exit roller | 18 Feed belt |

Pick-up Mechanism: Picks up the originals for scanning.

Feed/Separation Mechanism: Comprised of the feed belt and separation roller, feeds and separates the originals, and corrects skew.

Original Size Detection Sensors: Comprised of 4 width sensors and 2 length sensors, detect the sizes of the originals.

Original Transport Mechanism: Comprised of the transport roller, ADF exposure glass, and exit roller.

Original Reverse/Exit Mechanism: Exit/junction gate.

4.2 DRIVE LAYOUT

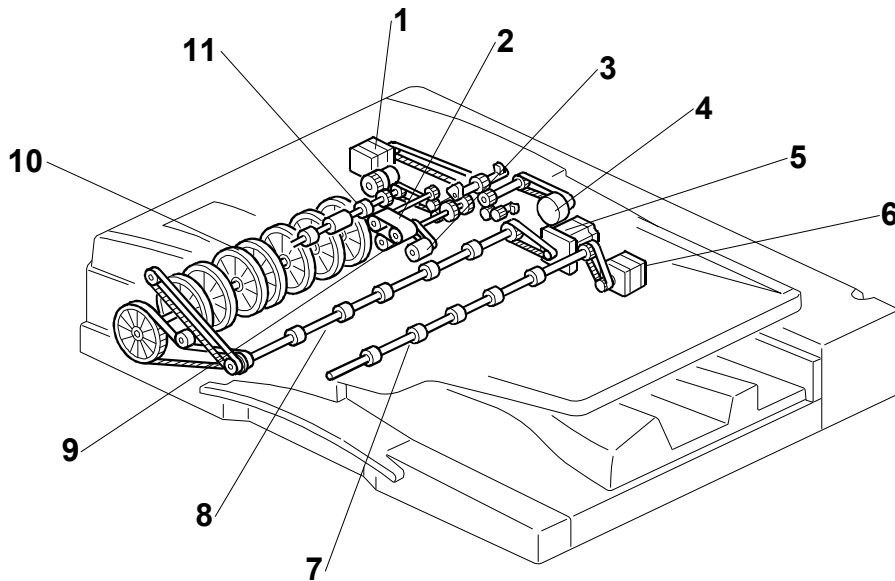

B597D102.WMF

- | | | | |
|---|-----------------|----|------------------------|
| 1 | Feed motor | 7 | Inverter roller |
| 2 | Feed belt | 8 | Exit roller |
| 3 | Pick-up roller | 9 | Separation roller |
| 4 | Pick-up motor | 10 | Transport roller |
| 5 | Transport motor | 11 | Skew correction roller |
| 6 | Inverter motor | | |

4.3 ORIGINAL SIZE DETECTION

4.3.1 BASIC MECHANISM

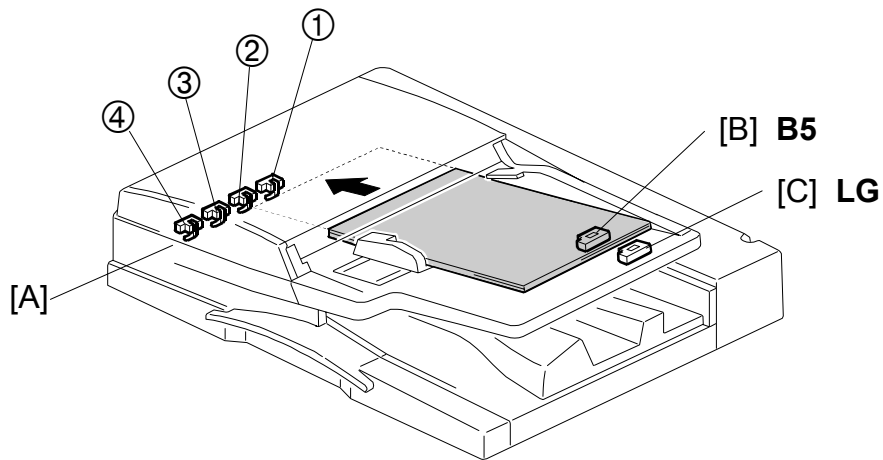

B597D110.WMF

The original size is detected by four original width sensors [A] and two original length sensors, [B] and [C].

The machine determines the original width when the leading edge of the original activates the registration sensor.

The ARDF detects the original size by combining the readings of the four width sensors and two length sensors, as shown in the table on the next page.

Size (Width x Length)	Width Sensor				Length Sensor	
	①	②	③	④	B5	LG
A3 L* ¹ (297 x 420 mm)	ON	ON	ON	ON	ON	ON
B4 L (257 x 364 mm)	ON	ON	-	-	ON	ON
A4 L (210 x 297 mm)	ON	-	-	-	ON	-
A4 S* ² (297 x 210 mm)	ON	ON	ON	ON	-	-
B5 L (182 x 257 mm)	-	-	-	-	ON	-
B5 S (257 x 182 mm)	ON	ON	-	-	-	-
A5 L (148 x 210 mm)	-	-	-	-	-	-
A5 S (210 x 148 mm)	ON	-	-	-	-	-
B6 L (128 x 182 mm)	-	-	-	-	-	-
B6 S (182 x 128 mm)	-	-	-	-	-	-
DLT L (11" x 17")	ON	ON	ON	-	ON	ON
11" x 15" L	ON	ON	ON	-	ON	ON
10" x 14" L	ON	ON	-	-	ON	ON
LG L (8 1/2" x 14")	ON	-	-	-	ON	ON
F4 L (8 1/2" x 13")	ON	-	-	-	ON	ON
F L (8" x 13")	ON	-	-	-	ON	ON
LT L (8.5" x 11")	ON	-	-	-	ON	-
LT S (11" x 8.5")	ON	ON	ON	-	-	-
7 1/4" x 10 1/2" L	-	-	-	-	ON	-
10 1/2" x 7 1/4" S	ON	ON	ON	-	-	-
8" x 10" L	ON	-	-	-	ON	-
HLT L 5 1/2" x 8 1/2"	-	-	-	-	-	-
HLT S 8 1/2" x 5 1/2"	ON	-	-	-	-	-
267 x 390 mm	ON	ON	ON	-	ON	ON
195 x 267 mm	ON	-	-	-	ON	-
267 x 195 mm	ON	ON	ON	-	-	-

*¹ L: Lengthways*² S: Sideways

ON: Paper present

4.3.2 MIXED ORIGINAL SIZE MODE

This section explains what happens when the user selects mixed original size mode.

Because this ADF is a sheet-through document feeder, the method for original document width detection is the same as when the originals are the same size, but the document length detection method is different. Therefore, the scanning speed is slightly slower.

Document length detection

From when the registration sensor switches on until the interval sensor switches off, the CPU counts the transport motor pulses. The number of pulses determines the length of the original.

Feed-in cycle

When the original size for the copy modes listed below cannot be determined, the image cannot be correctly scaled (reduced or enlarged) or processed until the document length has been accurately detected. The length must be determined before the image is scanned.

- Auto Reduce/Enlarge
- Centering
- Erase Center/Border
- Booklet
- Image Repeat

An original follows this path during transport:

1. Document length detection → Scanning glass → Inverter table
2. Inverter table → Scanning glass → Inverter table (restores original order)
3. Inverter table → Scanning glass (image scanned) → Exit tray

Normal feed-in

In a copy mode other than those listed above, when the rate of reduction/enlargement has been determined, the originals are scanned normally. In order to store the scanned images, a large area of memory (the detected document width x 432 mm) is prepared. Next, only the portion of the image up to the detected document length is read from memory and printed.

4.4 ORIGINAL FEED-IN MECHANISM

4.4.1 PICK-UP AND SEPARATION

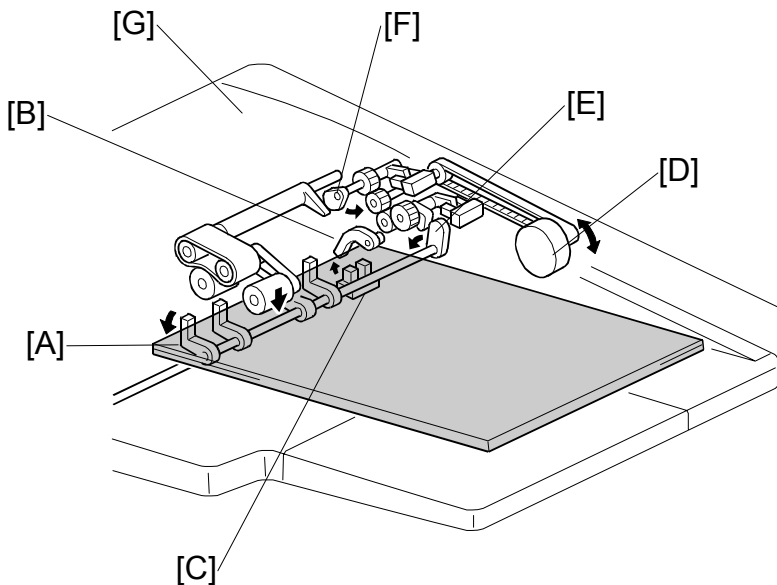

B597D109.WMF

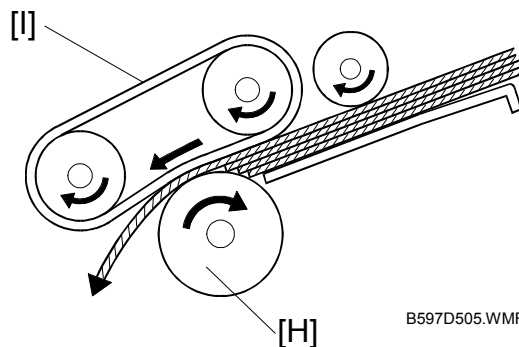

B597D505.WMF

When the original is put on the original table, it contacts the original stopper [A] and pushes the actuator [B] out of the original set sensor [C].

When Start  is pressed, the pick-up motor [D] turns on and the original stopper cam [E] rotates. The original stopper lowers and releases the original.

Next, the pick-up roller cam [F] lowers the pick-up roller, and then the feed motor [G] (at this location but not shown in the drawing) turns on to feed the top sheet of paper. After being fed from the pick-up roller, the top sheet is separated from the stack by the separation roller [H] and the feed belt [I].

4.4.2 ORIGINAL SKEW CORRECTION

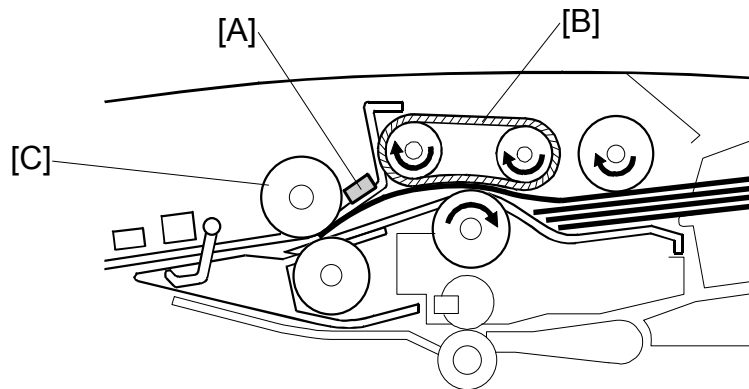

B597D202.WMF

This mechanism is the same as the skew correction used by the registration roller in the main machine.

The feed motor and the skew correction clutch control the skew correction roller. Immediately after separation, the skew correction sensor [A] detects the leading edge of the original. The feed belt [B] moves the paper slightly until it presses against the skew correction roller [C] and buckles slightly to correct any skew.

4.4.3 REDUCING THE INTERVAL BETWEEN PAGES

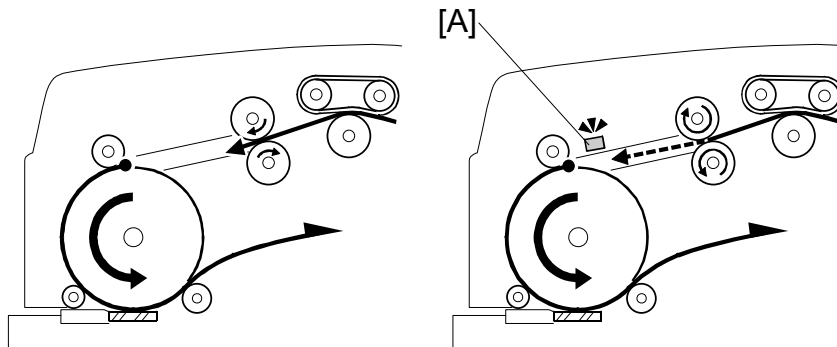

B597D303.WMF

After performing skew correction, the feed motor runs at a speed higher than its original speed in order for the next original to catch up to the one ahead of it. This reduces the gap between the leading edge of the next original with the trailing edge of the one ahead.

When the leading edge of the original activates the interval sensor [A], the feed motor slows to match the speed of paper transport.

4.5 ORIGINAL TRANSPORT AND EXIT

4.5.1 SINGLE-SIDED ORIGINALS

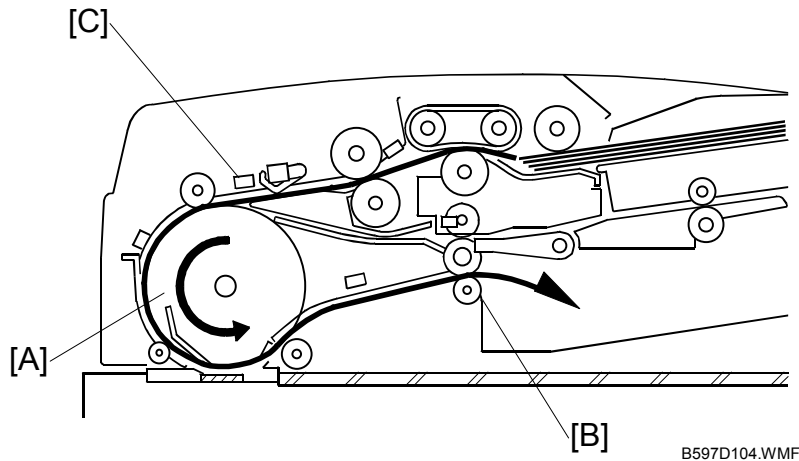

The transport motor drives the transport roller [A] and the exit roller [B]. When the leading edge of the original activates the interval sensor [C], the transport motor rotates the transport roller. The transport roller then feeds the original through scanning area. After scanning, the original is fed out by the exit roller to the exit tray.

4.5.2 DOUBLE-SIDED ORIGINALS

Shortly after the transport motor has been turned on, the inverter solenoid is activated and junction gate [A] opens. The original is then scanned and transported towards the reverse table [B].

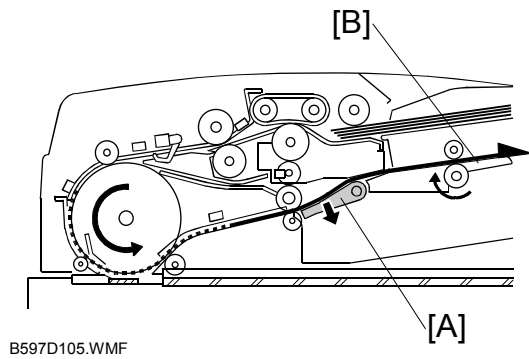

Shortly after the original exit sensor [C] detects the trailing edge of the original, the inverter solenoid turns off and the junction gate [D] closes.

Next, the inverter motor turns on and the inverter roller [E] starts rotating to feed the original from the reverse table.

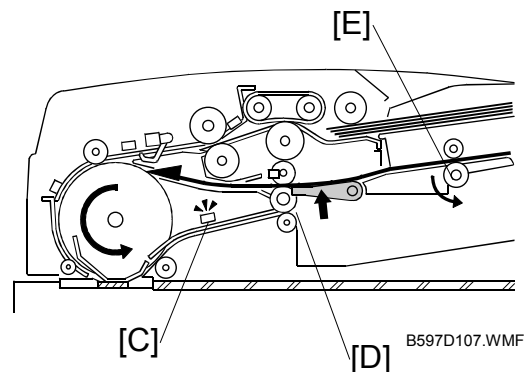

Then the original is fed to the transport roller and the scanning area [F] (where the reverse side is scanned).

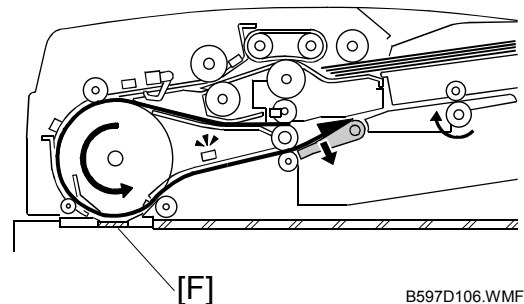

After scanning the reverse side of the original, the original is then sent to the reverse table [G] a second time and turned over. This ensures that the double-sided original will be properly stacked in the correct order, front side down, in the original exit tray [H].

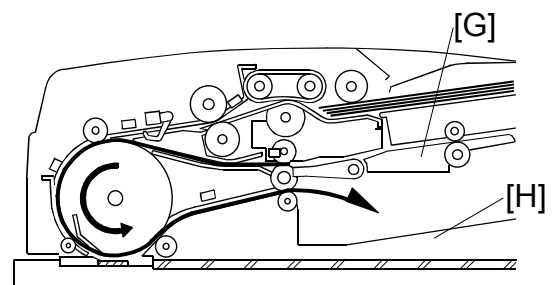

4.6 STAMP

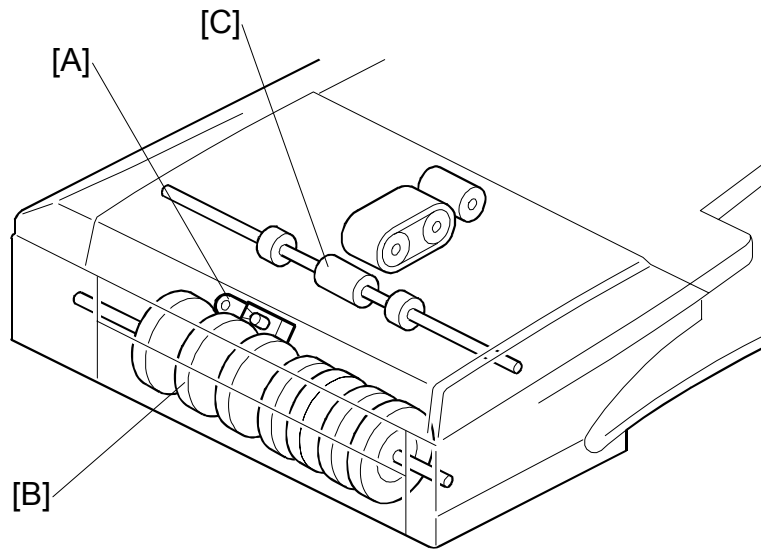

B597D201.WMF

NOTE: This function is only for fax mode.

The stamp [A] is located between the transport roller [B] and the exit roller [C].

When the original reaches the stamp, the transport motor stops and the stamp solenoid turns on if the page is sent successfully (immediate transmission) or stored successfully (memory transmission). After stamping, the ARDF feed motor re-starts to feed out the document.

NOTE: The position of the stamp can be adjusted with the Stamp Position Adjustment SP mode.